

# X Coordinate tables

Using the traditional robust BAZUS design, the range of manual coordinate tables are operated by trapezoidal spindles and dovetailed guides. Made from high quality stabilized cast iron, this product range comprises single axis (X) slide units.

## Vertical coordinate table (Z) for vertical positioning

Designed for precision work, the Z Series of vertical columns is optimal for positioning, vertical drilling, welding, and any other mechanical application where precise Z-position control is required.

The robust and robust design of the linear table allows a large number of jobs to be carried out while maintaining positioning precision and repeatability in any type of linear positioning. An industry classic that guarantees long life.

All Z Series elements are made of cast-iron (high quality GG25 stabilized gray cast iron), giving it extraordinary mechanical rigidity.

---

### Technical details:

- Displacement by dovetails with clearance adjustment (all surfaces grinding finishment)
- Millimeter rulers and matte chrome vernier, with dial and zero adjustment.
- Trapezoidal threaded spindle with adjustable spindle nut.
- Locking brake to fix the Z column in its working position

The Z series offers 2 models of coordinate tables of different sizes, from 300 to 500 mm of useful travel, in order to adapt to the needs of the application and offer flexibility and adaptation to different uses and applications: all types of machine tools , drills, grinding machines, sharpening machines, mortising machines, lathes, optical and laser systems, positioning of work heads, adjustment and position regulation of parts in presses, displacement for welding cutting, industrial engraving.

### BAZUS commitment:

- The highest quality, robust and durable coordinate tables on the market.
- Tables with the finest linear positioning and without spindle-play.
- Coordinate tables made 100% in Europe.

### Customized solutions:

BAZUS, your trusted partner for high-performance positioning systems, provides the right solution for any application, specifically designed or customized to the characteristics and requirements of your activity.

Whatever your coordinate table, thanks to more than 100 years of continuous improvement, you will have a partner who offers solutions to all your positioning and movement requirements with many different applications available worldwide.

### The first guarantee, for 5 years:

Why settle for a 2 year warranty? At BAZUS we believe that, if the coordinate tables do not expire at this time, neither should the professional attention received. So once again we want to change the rules. 5 year guarantee.

# Z-300

Z, Vertical column Z

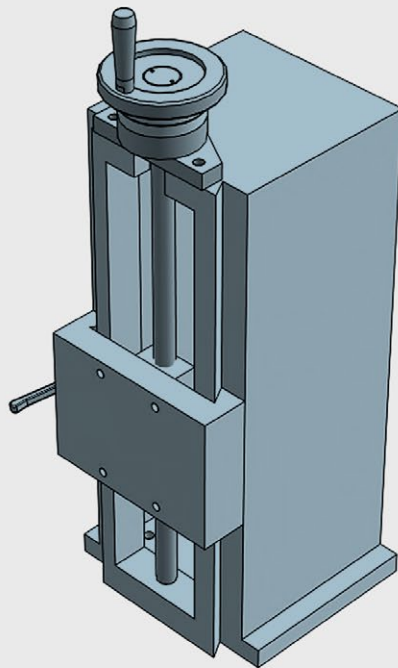

VERTICAL axis table for applications with linear units. Can be used only in vertical position All elements in stabilized cast iron GG25. All surfaces with grinded finishment. Millimetered rules in XY. Vernier/nonuis matt chrome. Dial, with zero setting. Spindle with trapezoidal thread. Adjustable spindle nut. Standard lock in XY (M6 screw to block the dovetailed guides in working position)

## Vertical unit travelling 300

### Technical Specifications

X - Travel [mm]	300
Y - Travel [mm]	-
Resolution [mm]	0,05
Max. weight [kg]	30
Max. work pres. [kg]	300
Weight [kg]	38

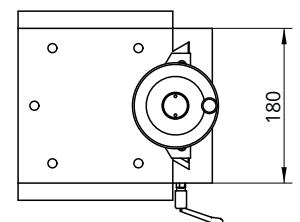
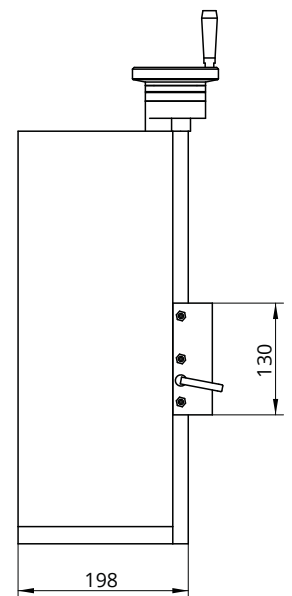
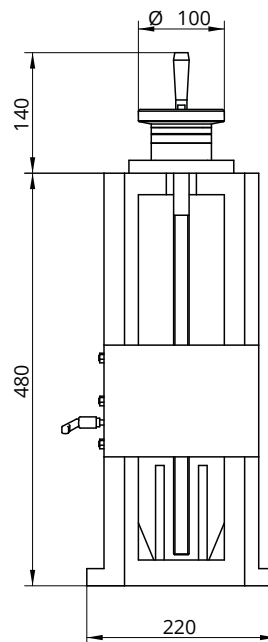

# Z-800

Z, Vertical column Z

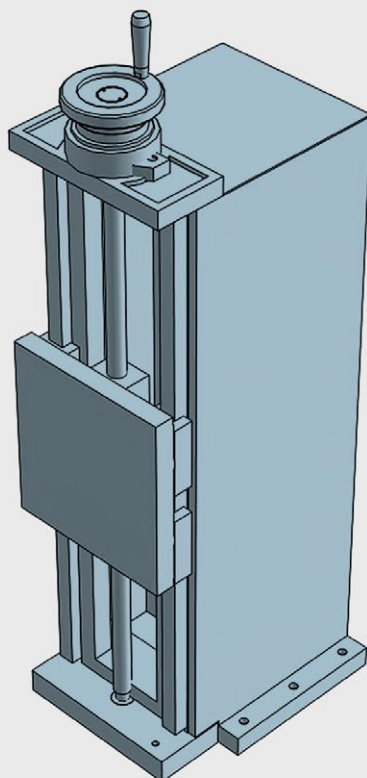

VERTICAL axis table for applications with linear units. Can be used only in vertical position All elements in stabilized cast iron GG25. All surfaces with grinded finishment. Millimetered rules in XY. Vernier/nonuis matt chrome. Dial, with zero setting. Spindle with trapezoidal thread. Adjustable spindle nut. Standard lock in XY (M6 screw to block the dovetailed guides in working position)

## Vertical unit travelling 500

### Technical Specifications

X - Travel [mm]	500
Y - Travel [mm]	-
Resolution [mm]	0,05
Max. weight [kg]	90
Max. work pres. [kg]	500
Weight [kg]	160

