

CNC Coordinate tables

The BAZUS automatic series has been developed for automated industrial process applications. The system is designed mechanically and electrically according to the degree of automation required and the precision and repeatability needed.

X single-axis multifunctional lightweight automatic linear unit for professional use.

Designed for high-precision automatic works, the PK series are optimal linear units for all types of automatic movement in any industrial environment: drilling, milling, grinding, welding, transfer systems, industrial engraving, automatic positioning of laser and optical systems, movement of tool holder and / or autonomous heads, as well as in any other mechanical application where an automatic control of the X position is necessary.

Its solid and robust design allows a large number of jobs to be carried out while maintaining complete adjustment and positioning accuracy and high repeatability in any type of linear positioning. A coordinate table that excels in the industry for its excellence.

All the elements of the PK series automatic coordinate tables are made of cast iron (high-quality stabilized gray GG25 cast iron), which gives it extraordinary mechanical rigidity.

Technical details:

- High precision, versatility and long life of components and accessories.
- It stands out for its versatility in many different uses or situations.
- Linear movement, with low resistance to friction.
- Movement by means of dovetail guides with turcrite to obtain a very low coefficient of friction (all surfaces grinding finishment) and great mechanical rigidity against vibration.
- Servobrushless motors with encoder.
- Ball recirculation spindles with double preloaded nut.
- Synchronization with external devices (head, cooling pump, etc...)
- Software and interface included.

The PK series of automatic tables offer 6 models of different sizes, from 110 mm to 384 mm of useful travelling, in order to be able to adapt to the various requirements and / or different uses and applications: all kinds of machine tools, drills, grinding machines, sharpening machines, milling machines, lathes, linear optical and laser systems, positioning of work heads , adjustment and position regulation of parts in presses, displacement for welding cutting and industrial engraving.

BAZUS commitment:

- The highest quality, robust and durable coordinate tables on the market.
- Tables with the finest linear positioning and without spindle-play.
- Coordinate tables made 100% in Europe.

Customized solutions:

BAZUS, your trusted partner for high-performance positioning systems, provides the right solution for any application, specifically designed or customized to the characteristics and requirements of your activity.

Whatever your coordinate table, thanks to more than 100 years of continuous improvement, you will have a partner who offers solutions to all your positioning and movement requirements with many different applications available worldwide.

The first guarantee, for 5 years:

Why settle for a 2 year warranty? At BAZUS we believe that, if the coordinate tables do not expire at this time, neither should the professional attention received. So once again we want to change the rules. 5 year guarantee.

PK-1

PK Automatic X slide unit (horizontal or vertical)

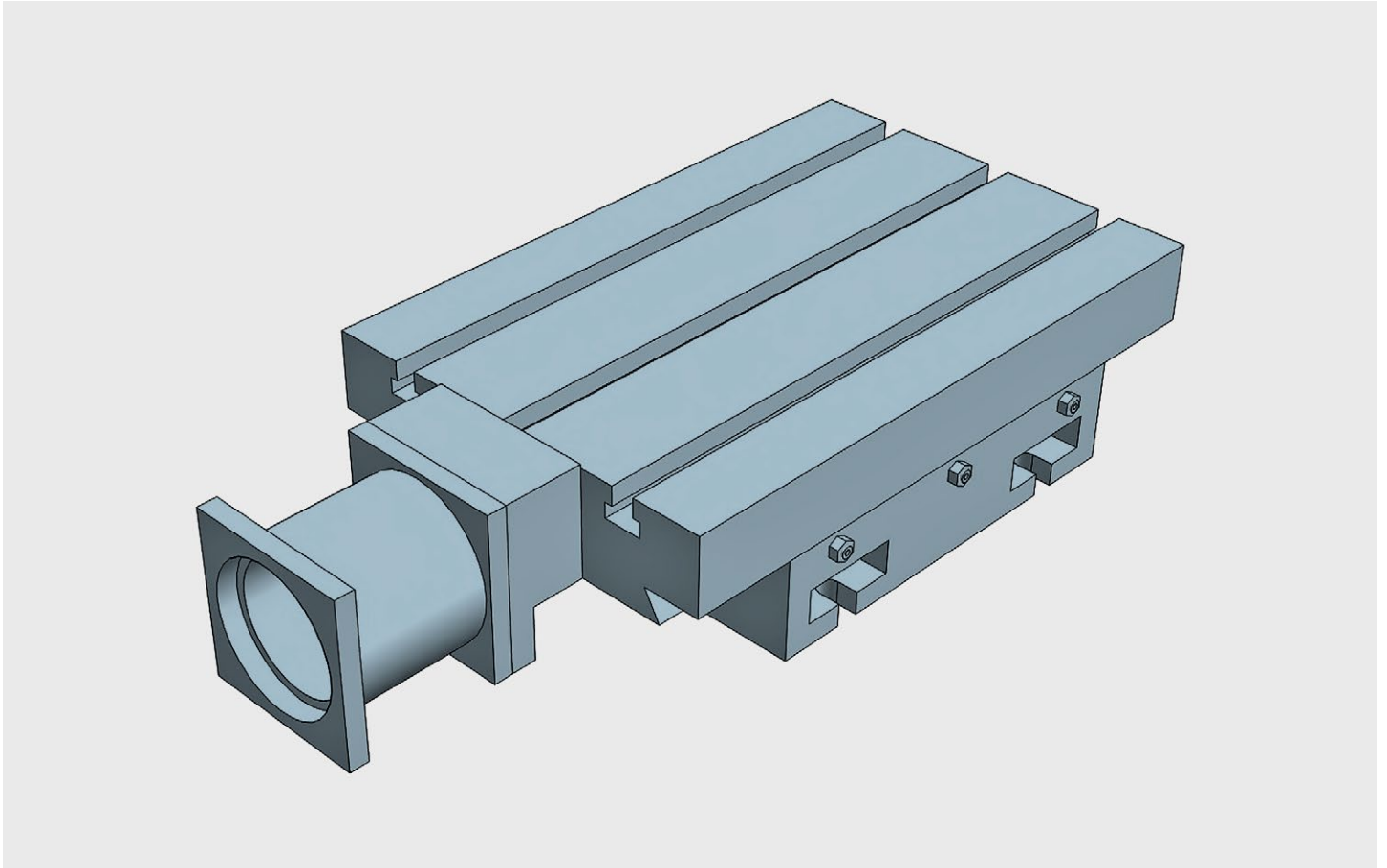

Single automatic X unit. All elements in stabilized cast iron GG25. All surfaces with grinded finishment. Ballbearing spindles with double nut. Dovetailed guides with turcite. Any CNC available under request

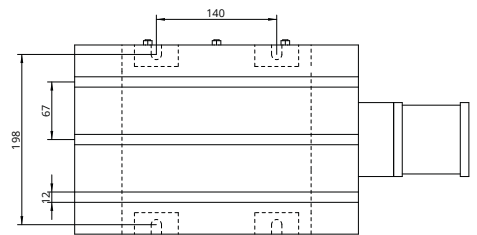
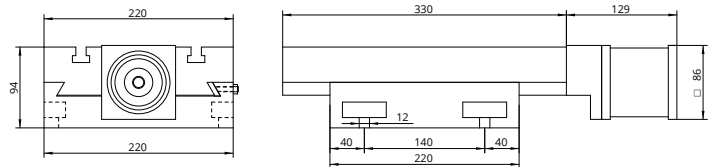

Automatic slide table travelling 110

Technical Specifications

X - Travel [mm]	110
Y - Travel [mm]	-
Tolerance CNC [mm]	+/- 0,01
Max. weight [kg]	105
Max. work pres. [kg]	700
Weight [kg]	25

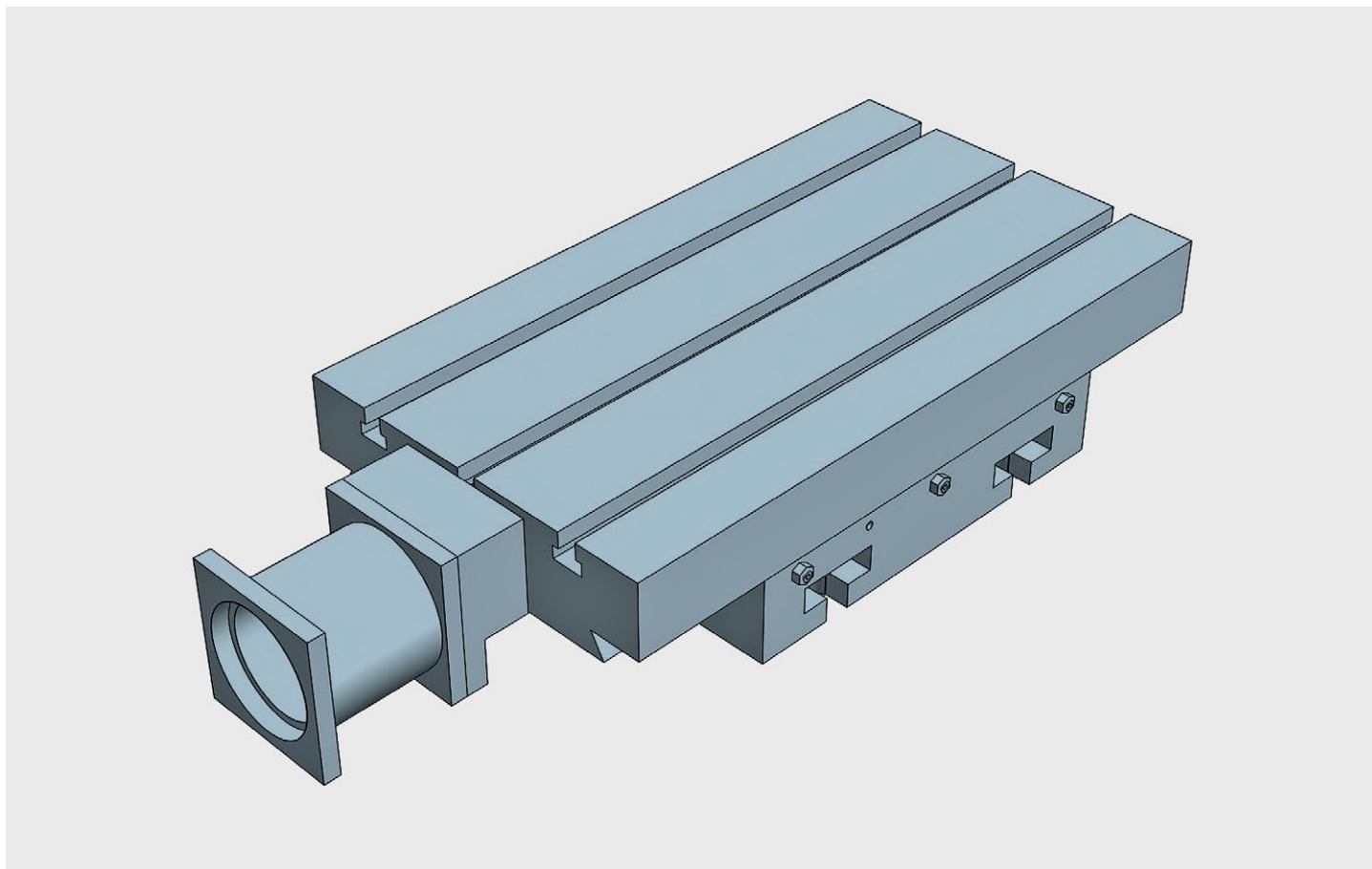

Single automatic X unit. All elements in stabilized cast iron GG25. All surfaces with grinded finishment. Ballbearing spindles with double nut. Dovetailed guides with turcite. Any CNC available under request

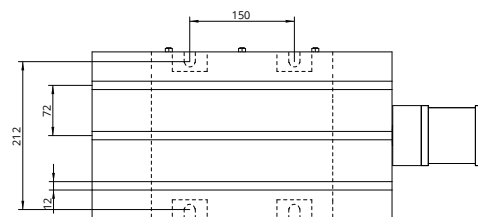
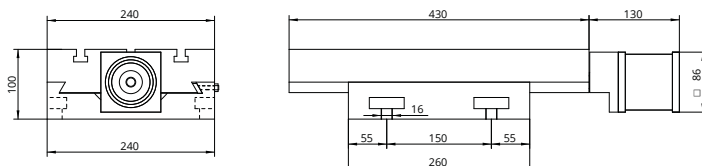

Automatic slide table travelling 170

Technical Specifications

X - Travel [mm]	170
Y - Travel [mm]	-
Tolerance CNC [mm]	+/- 0,01
Max. weight [kg]	270
Max. work pres. [kg]	900
Weight [kg]	35

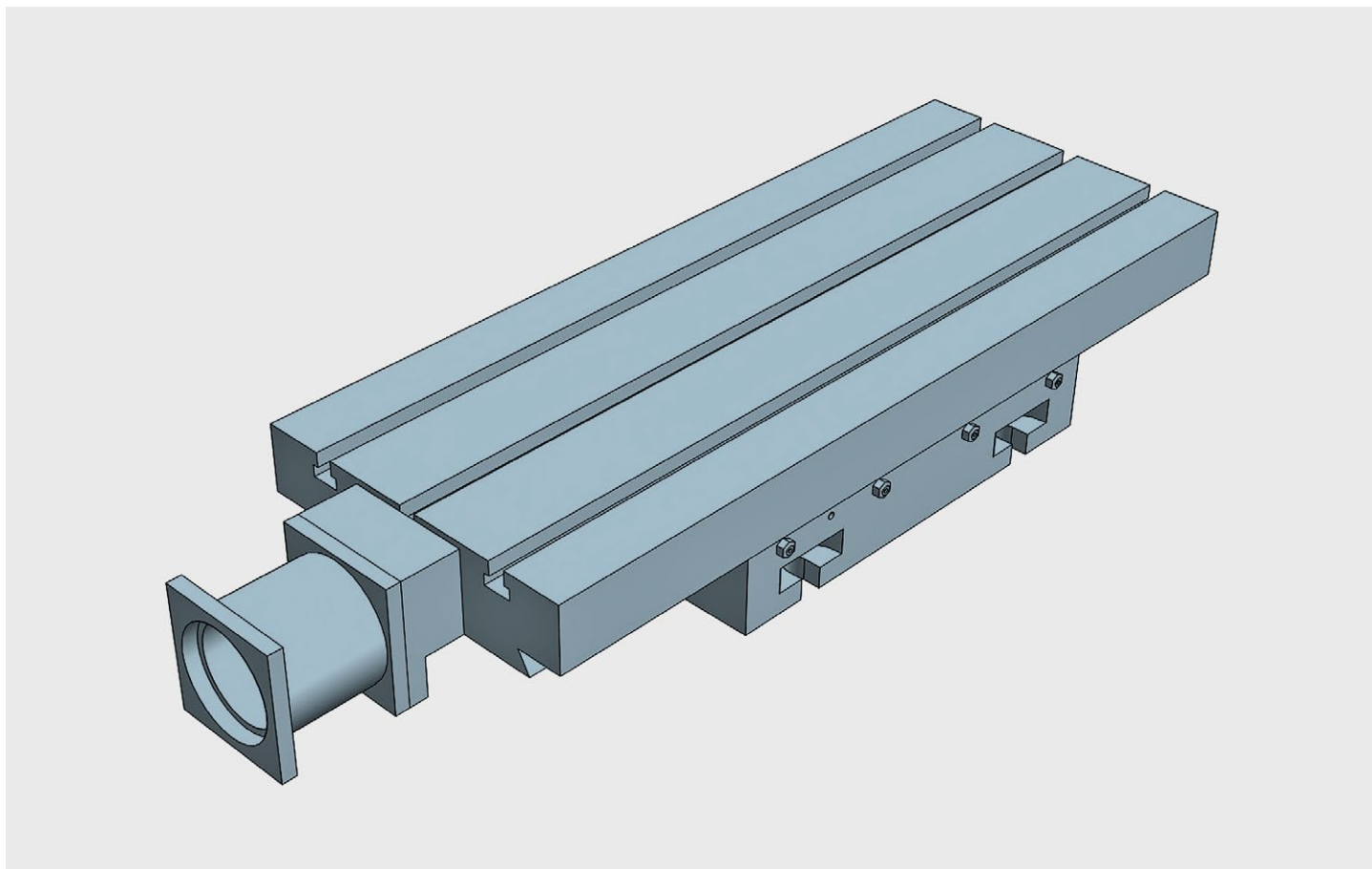

Single automatic X unit. All elements in stabilized cast iron GG25. All surfaces with grinded finishment. Ballbearing spindles with double nut. Dovetailed guides with turcite. Any CNC available under request

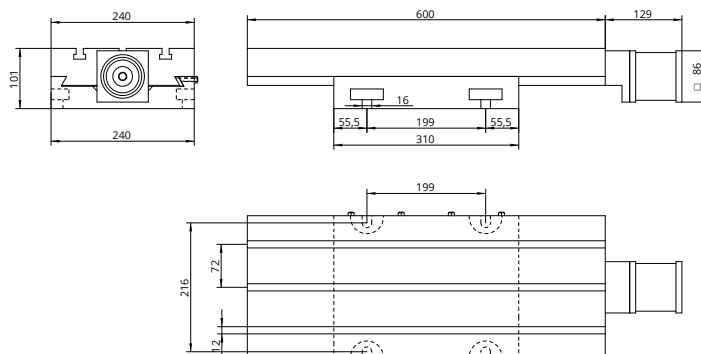

Automatic slide table travelling 290

Technical Specifications

X - Travel [mm]	290
Y - Travel [mm]	-
Tolerance CNC [mm]	+/- 0,01
Max. weight [kg]	270
Max. work pres. [kg]	980
Weight [kg]	45

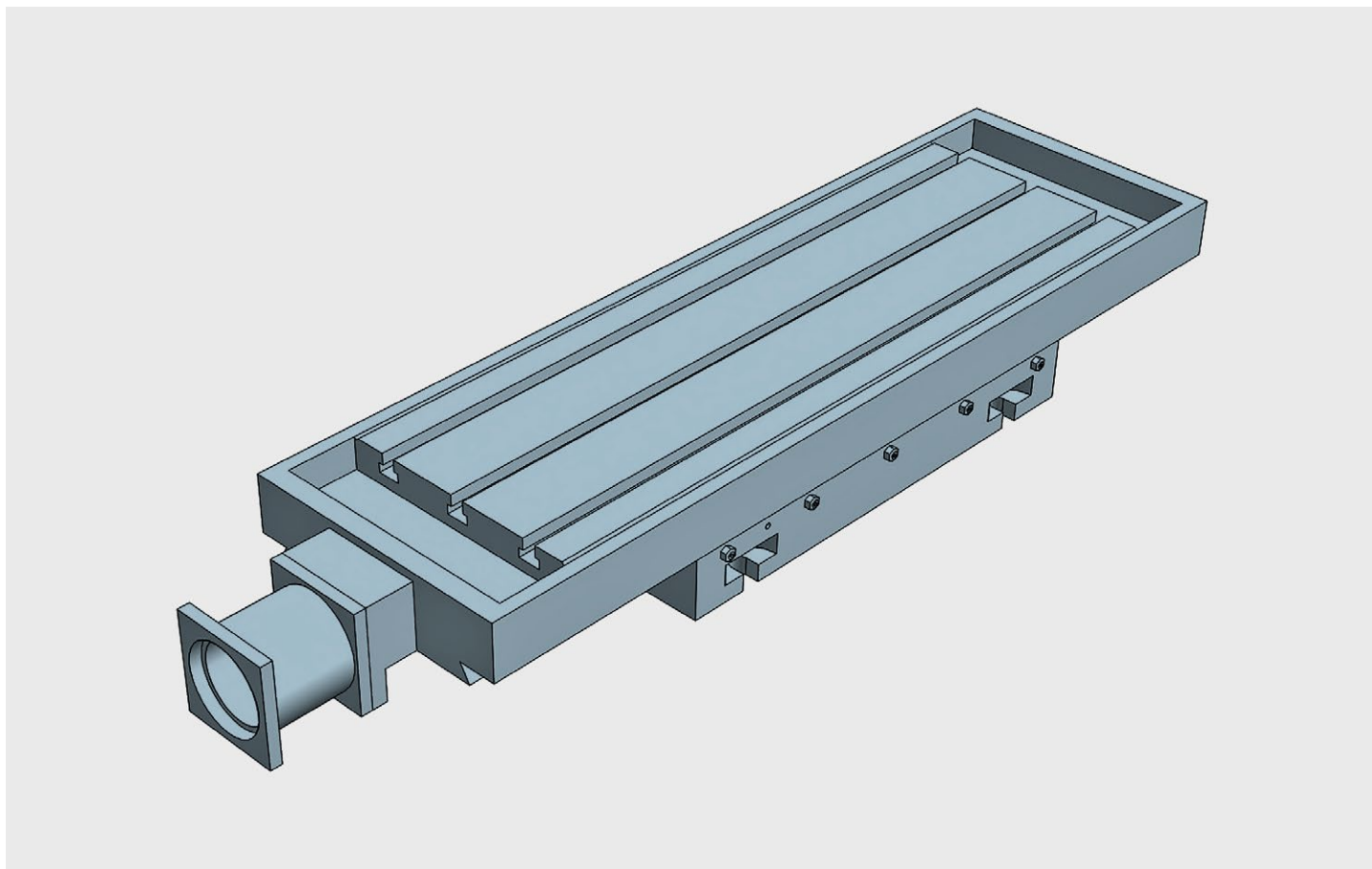

Single automatic X unit. All elements in stabilized cast iron GG25. All surfaces with grinded finishment. Ballbearing spindles with double nut. Dovetailed guides with turcite. Any CNC available under request

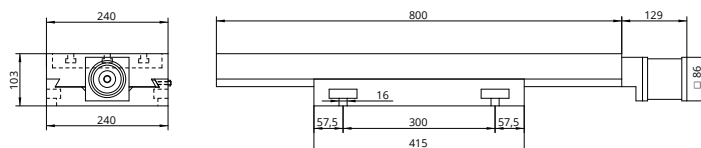

Automatic slide table travelling 385

Características técnicas

Recorrido X [mm]	385
Recorrido Y [mm]	-
Tolerancia CNC [mm]	+/- 0,01
Máx. peso [kg]	290
Máx. presión trabajo [kg]	1200
Peso [kg]	62

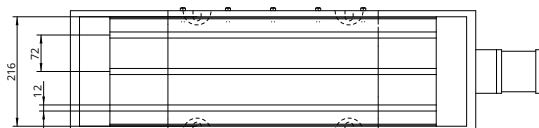

PK-5

PK Automatic X slide unit (horizontal or vertical)

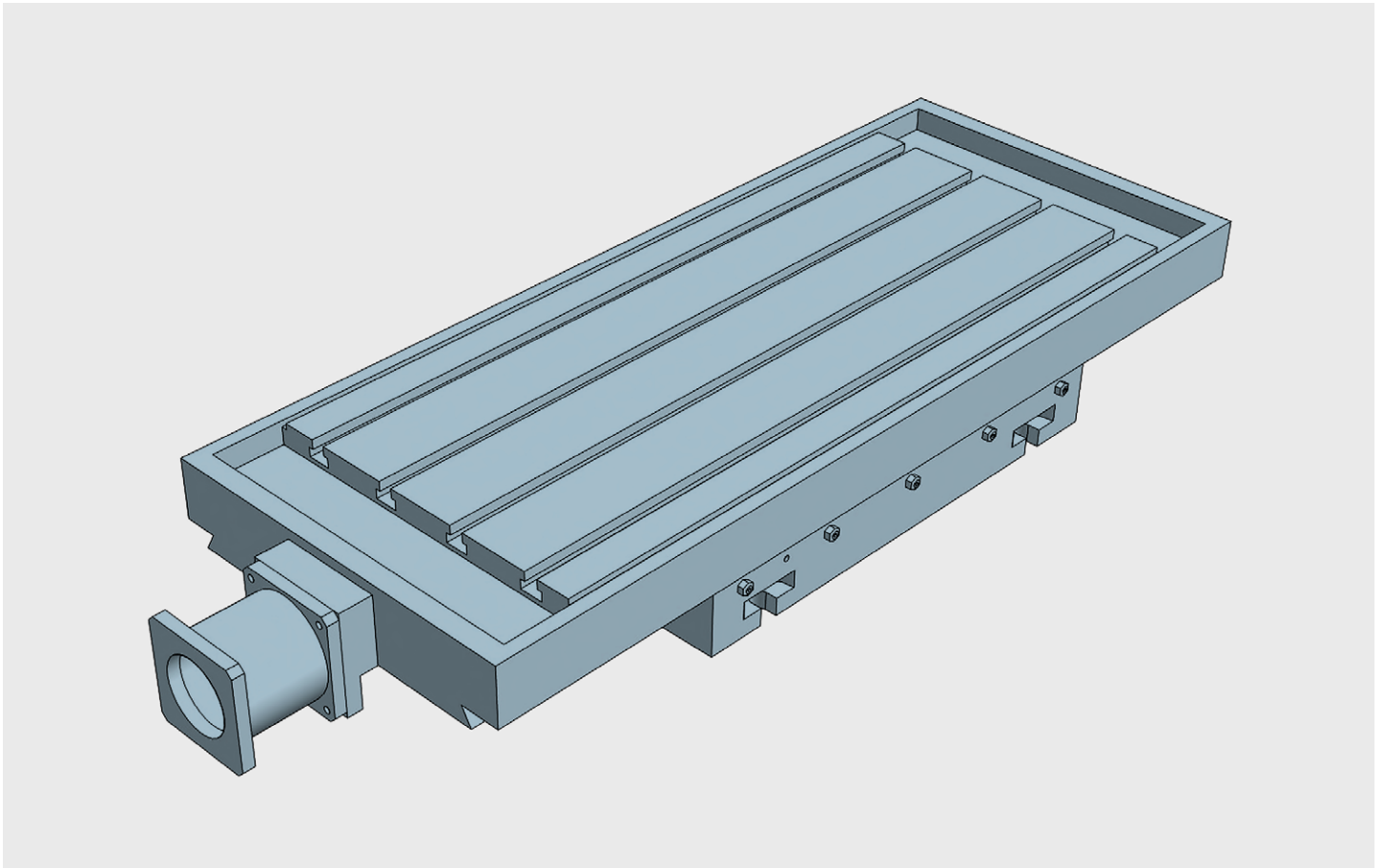

Single automatic X unit. All elements in stabilized cast iron GG25. All surfaces with grinded finishment. Ballbearing spindles with double nut. Dovetailed guides with turcite. Any CNC available under request

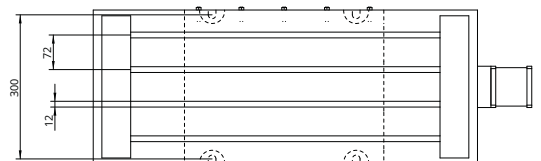
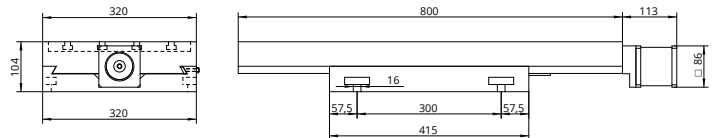

Automatic slide table travelling 385

Technical Specifications

X - Travel [mm]	385
Y - Travel [mm]	-
Tolerance CNC [mm]	+/- 0,01
Max. weight [kg]	290
Max. work pres. [kg]	1200
Weight [kg]	85