

XY Coordinate tables

Fixed double axis cross tables, designed to be used on drilling and milling machines, special transfer assemblies and in any mechanical application in which X-Y movement has to be controlled.

Two-axis XY multifunctional coordinate table with rotary underbasis for professional use

Designed for high precision jobs where, in addition to exact control of the XY position, an angular positioning is also necessary. Application in pad printing machines, special machines, milling machines, head positioning and any other mechanical application where XY position and G angle control are necessary.

The lower base allows 360° angular positioning by manual rotation of the XY table on a central axis. It includes engraving of a graduated sector of 180 to be able to measure the angular positioning.

All the elements of the MG series manual coordinate tables are made of cast iron alloy (high-quality stabilized gray GG25 cast iron), which gives it extraordinary mechanical rigidity.

Technical details:

- Displacement by dovetails with clearance adjustment (all surfaces grinding finishment)
- Millimeter rulers and matte chrome vernier, with dial and zero adjustment.
- Trapezoidal threaded spindle with adjustable spindle nut.
- Locking brake to fix the XY table in its working position
- Screw for locking and unlocking the central bolt for angular positioning

The MG series rotary table offers 6 models of different sizes, from 120x110 mm with 470x300 mm of useful travelling, in order to adapt to the needs of the application and offer flexibility and adaptation to different uses and applications: all types of machine tools, special positioning and adjustment systems, tools, on-site machining, positioning of pad printing, cutting and sharpening heads.

BAZUS commitment:

- The highest quality, robust and durable coordinate tables on the market.
- Tables with the finest linear positioning and without spindle-play.
- Coordinate tables made 100% in Europe.

Customized solutions:

BAZUS, your trusted partner for high-performance positioning systems, provides the right solution for any application, specifically designed or customized to the characteristics and requirements of your activity.

Whatever your coordinate table, thanks to more than 100 years of continuous improvement, you will have a partner who offers solutions to all your positioning and movement requirements with many different applications available worldwide.

The first guarantee, for 5 years:

Why settle for a 2 year warranty? At BAZUS we believe that, if the coordinate tables do not expire at this time, neither should the professional attention received. So once again we want to change the rules. 5 year guarantee.

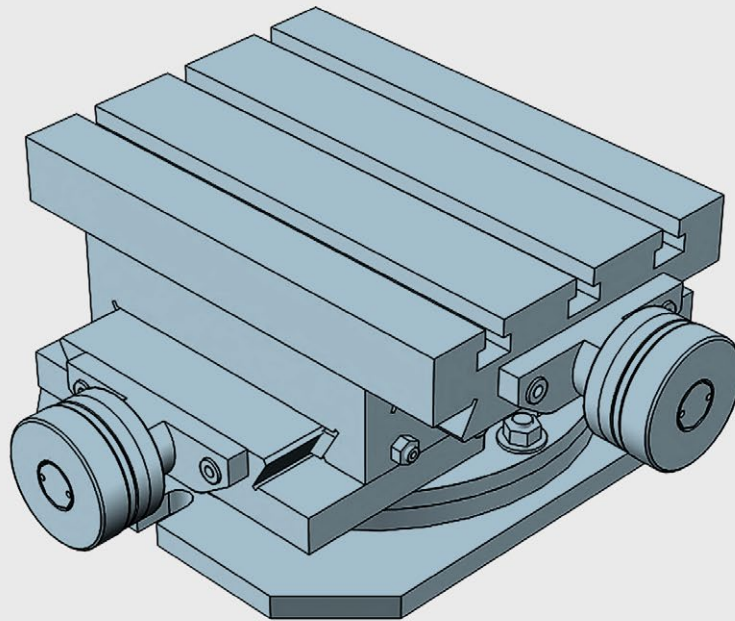

Double axis crosstable with rotary basis: the swivel support base comes with 180° in order to carry out angled works. All elements in stabilized cast iron GG25. All surfaces with grinded finishment. Millimetered rules in XY. Vernier/nonuis matt chrome. Dial, with zero setting. Spindle with triangular thread. Adjustable spindle nut. Standard lock in XY (M6 screw to block the dovetailed guides in working position)

Rotary crosstable XY travelling 120x110

Technical Specifications

X - Travel [mm]	120
Y - Travel [mm]	110
Resolution [mm]	0,05
Max. weight [kg]	55
Max. work pres. [kg]	500
Weight [kg]	22

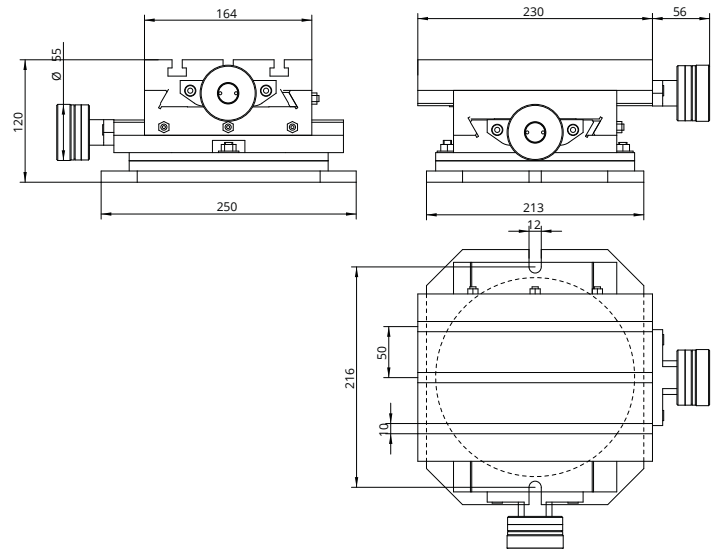

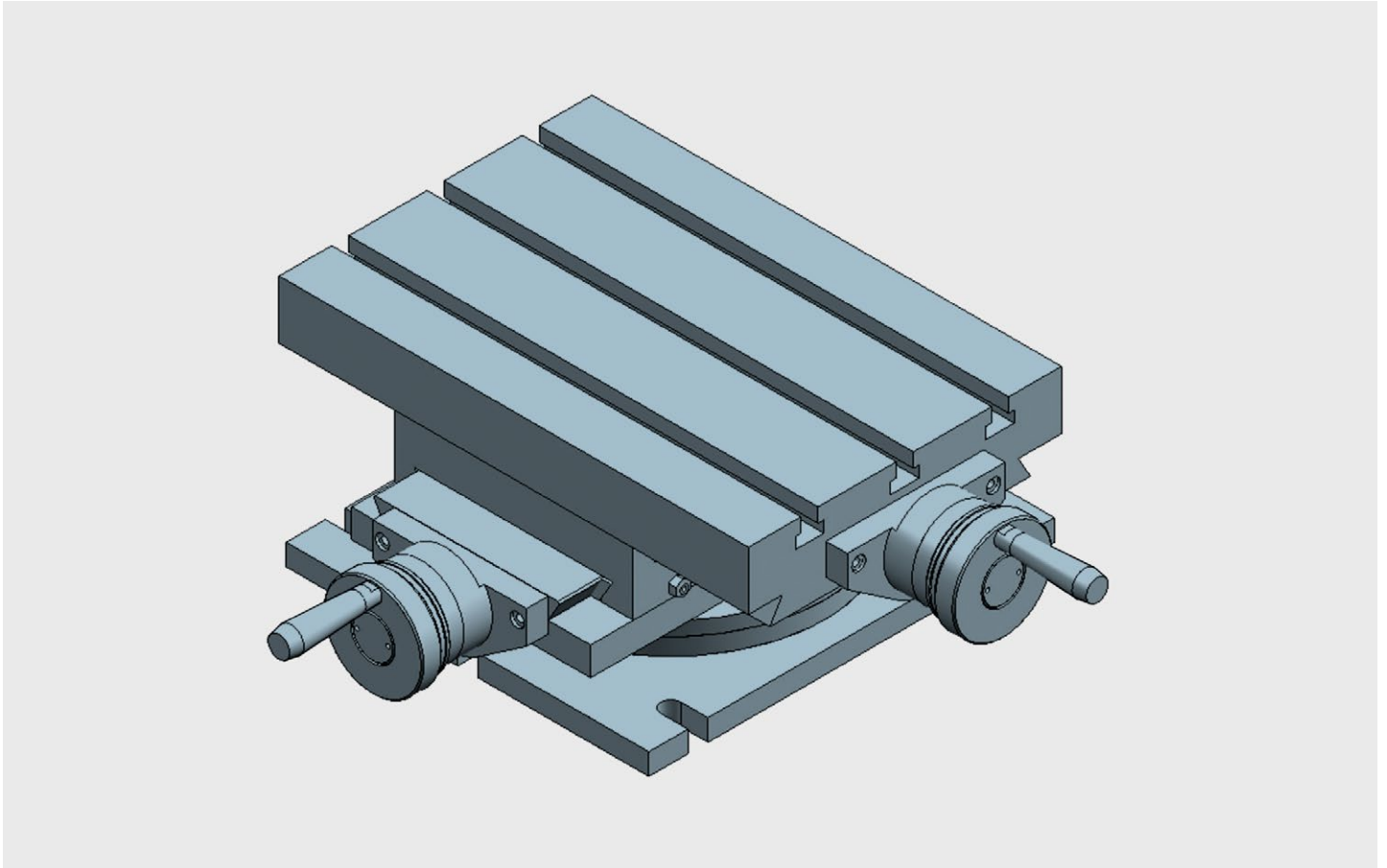

Double axis crosstable with rotary basis: the swivel support base comes with 180° in order to carry out angled works. All elements in stabilized cast iron GG25. All surfaces with grinded finishment. Millimetered rules in XY. Vernier/nonuis matt chrome. Dial, with zero setting. Spindle with trapezoidal thread. Adjustable spindle nut. Standard lock in XY (M6 screw to block the dovetailed guides in working position)

Rotary crosstable XY travelling 190x130

Technical Specifications

X - Travel [mm]	190
Y - Travel [mm]	130
Resolution [mm]	0,05
Max. weight [kg]	105
Max. work pres. [kg]	700
Weight [kg]	38

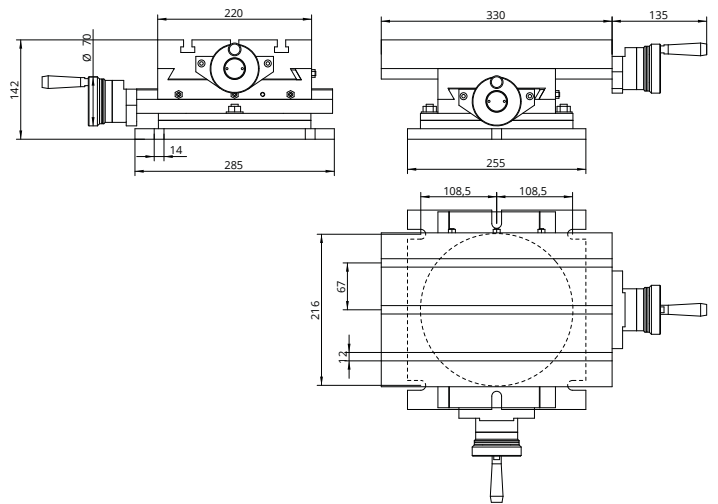

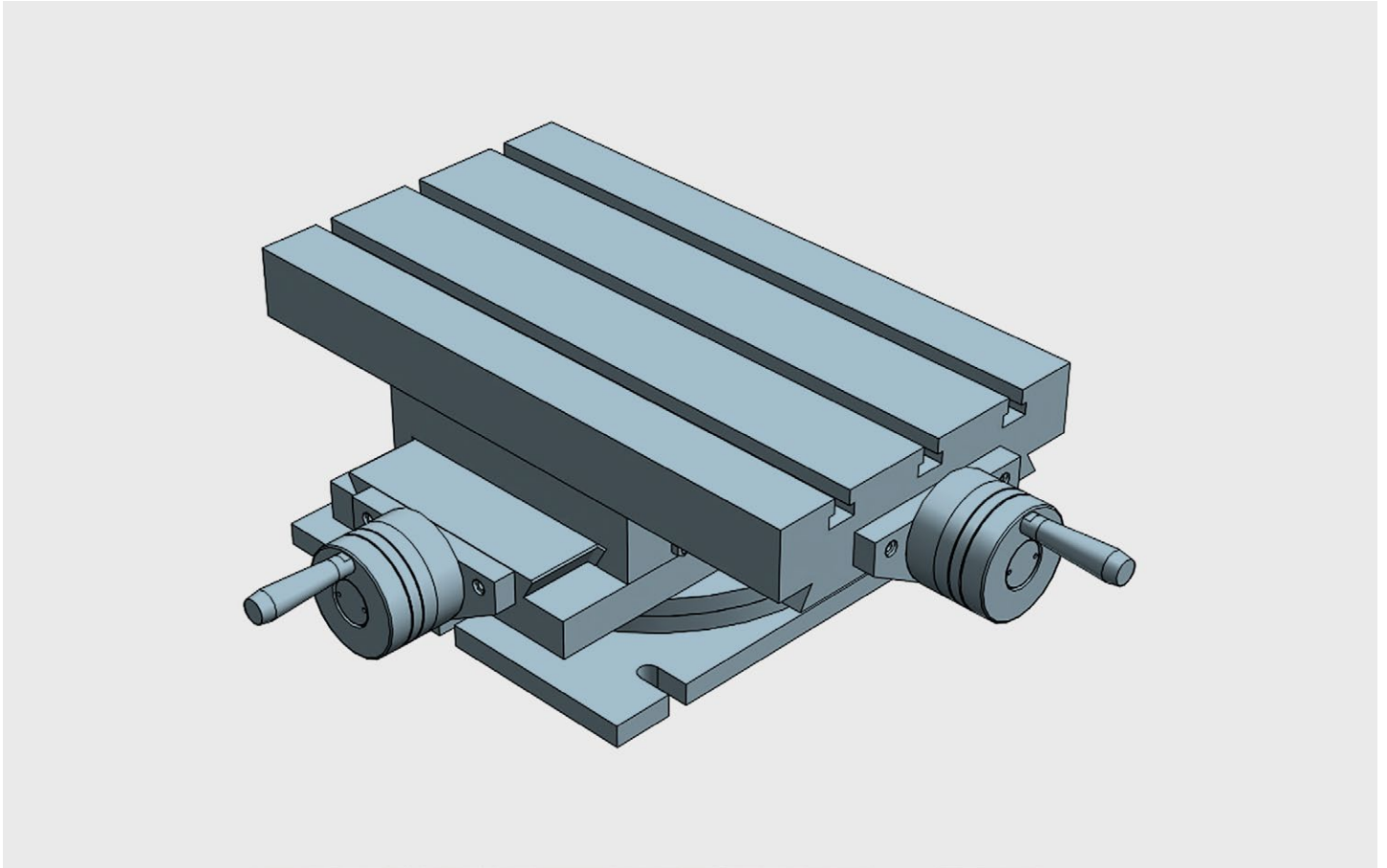

Double axis crosstable with rotary basis: the swivel support base comes with 180° in order to carry out angled works. All elements in stabilized cast iron GG25. All surfaces with grinded finishment. Millimetered rules in XY. Vernier/nonuis matt chrome. Dial, with zero setting. Spindle with trapezoidal thread. Adjustable spindle nut. Standard lock in XY (M6 screw to block the dovetailed guides in working position)

Rotary crosstable XY travelling 240x160

Technical Specifications

X - Travel [mm]	240
Y - Travel [mm]	160
Resolution [mm]	0,05
Max. weight [kg]	270
Max. work pres. [kg]	900
Weight [kg]	55

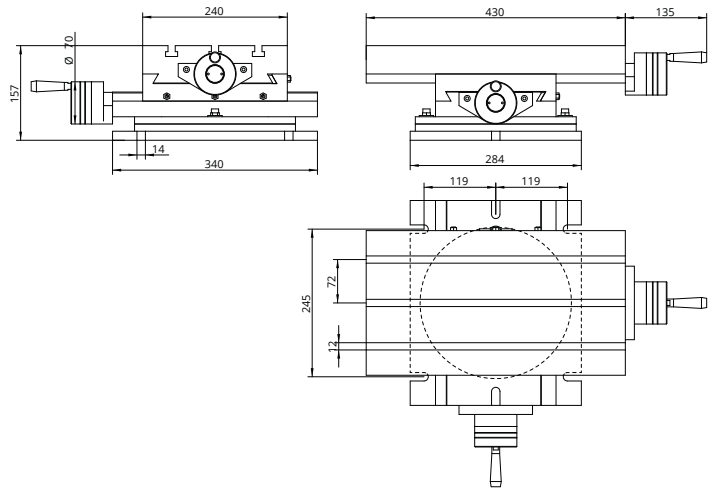

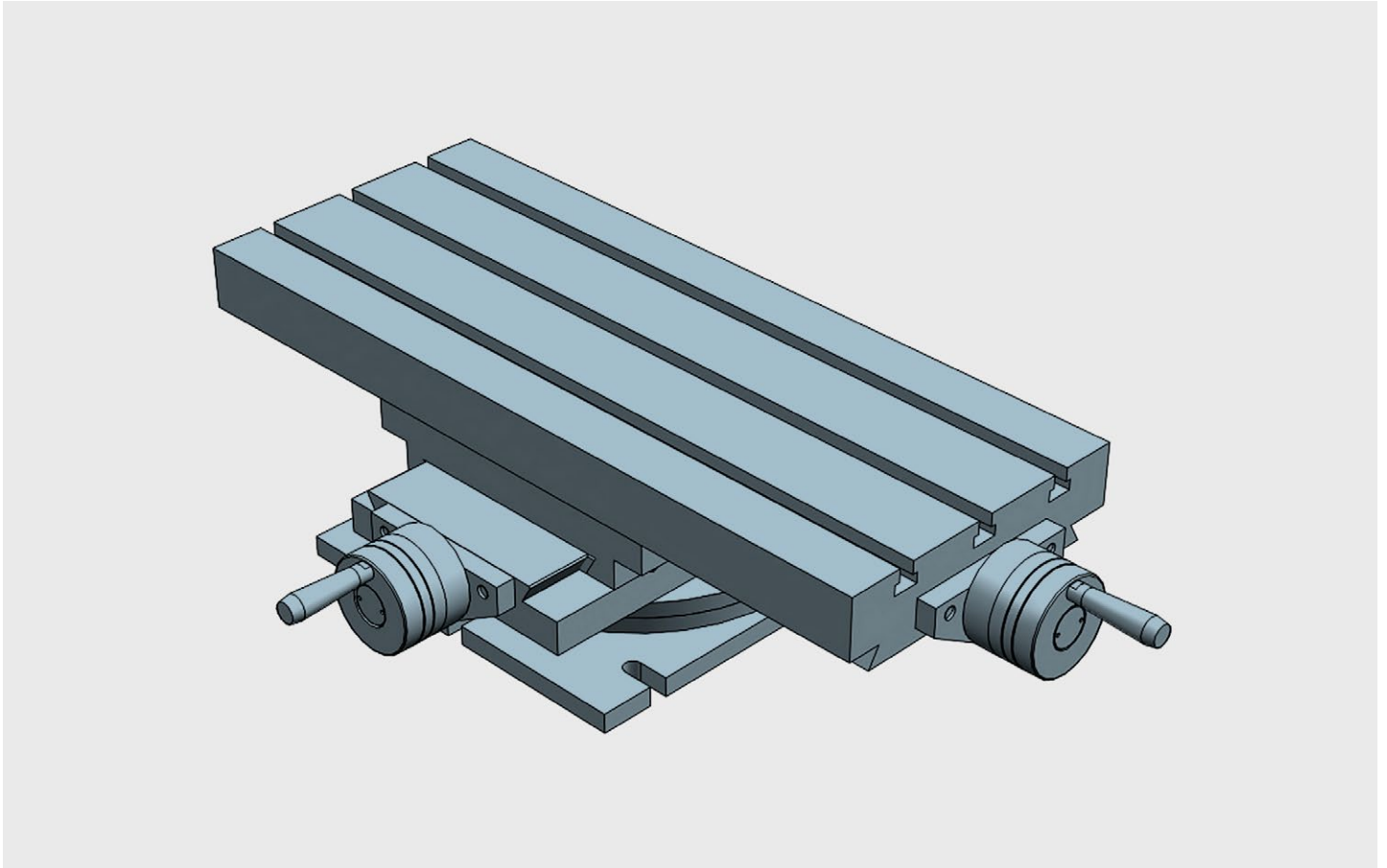

Double axis crosstable with rotary basis: the swivel support base comes with 180° in order to carry out angled works. All elements in stabilized cast iron GG25. All surfaces with grinded finishment. Millimetered rules in XY. Vernier/nonuis matt chrome. Dial, with zero setting. Spindle with trapezoidal thread. Adjustable spindle nut. Standard lock in XY (M6 screw to block the dovetailed guides in working position)

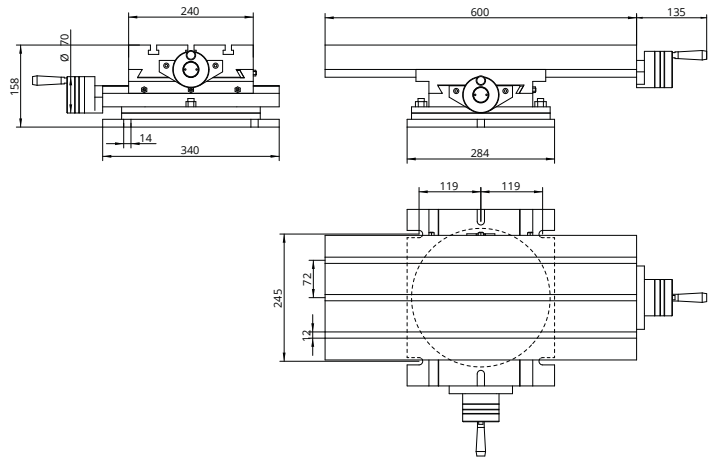

Rotary crosstable XY travelling 350x160

Technical Specifications

X - Travel [mm]	350
Y - Travel [mm]	160
Resolution [mm]	0,05
Max. weight [kg]	270
Max. work pres. [kg]	980
Weight [kg]	65

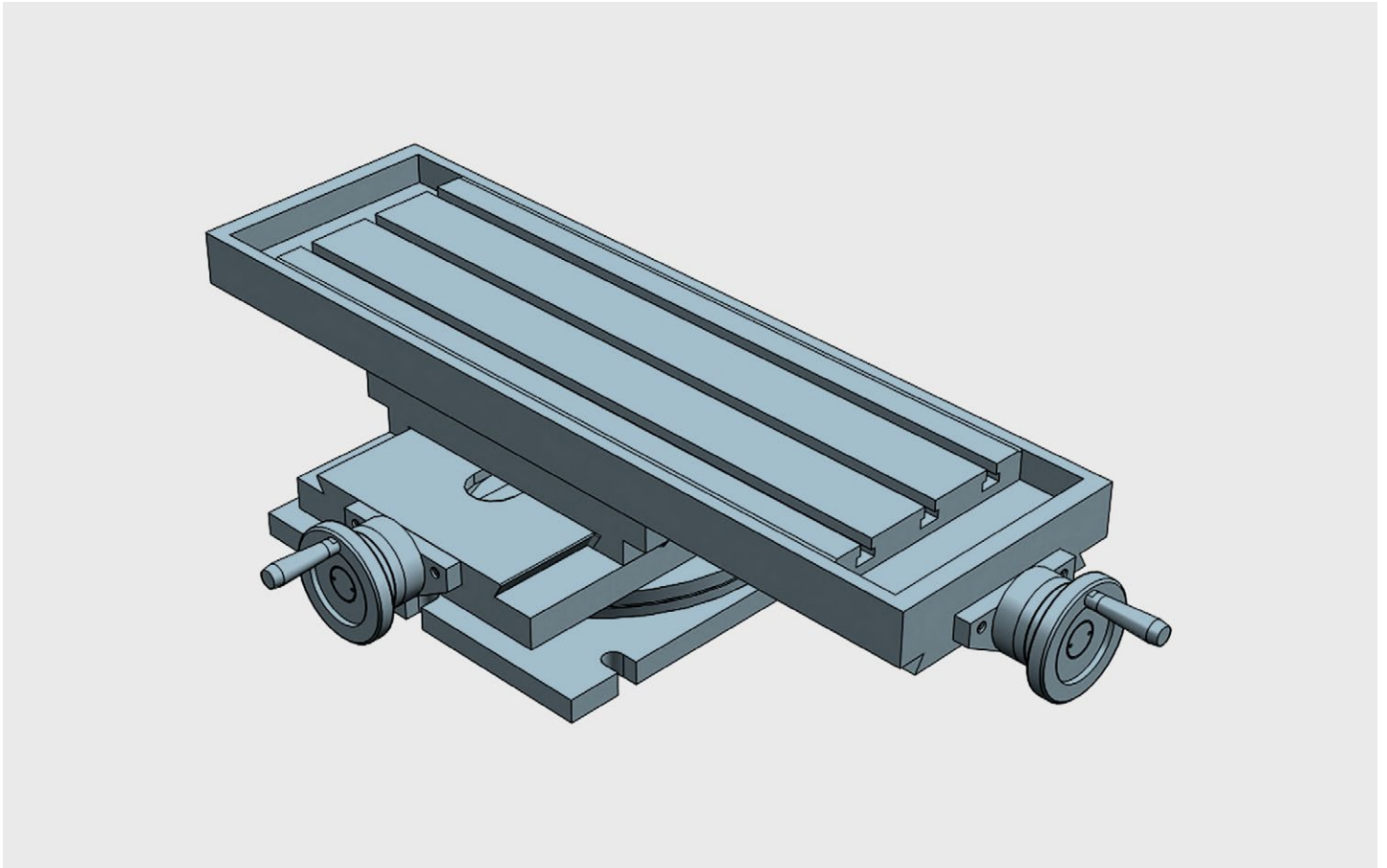

Double axis crosstable with rotary basis: the swivel support base comes with 180° in order to carry out angled works. All elements in stabilized cast iron GG25. All surfaces with grinded finishment. Millimetered rules in XY. Vernier/nonuis matt chrome. Dial, with zero setting. Spindle with trapezoidal thread. Adjustable spindle nut. Standard lock in XY (M6 screw to block the dovetailed guides in working position)

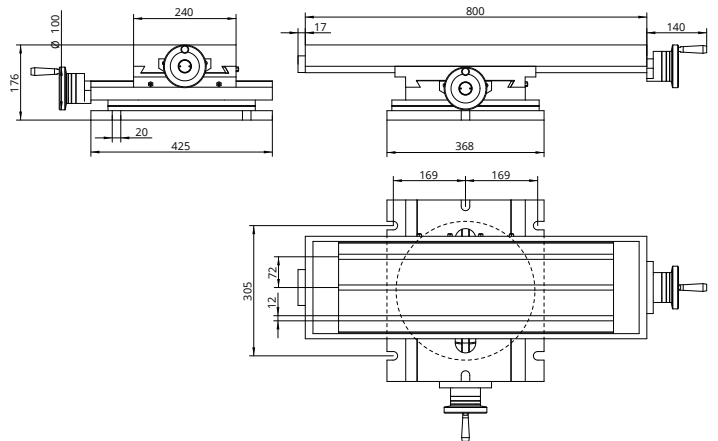

Rotary crosstable XY travelling 470x240

Technical Specifications

X - Travel [mm]	470
Y - Travel [mm]	240
Resolution [mm]	0,05
Max. weight [kg]	290
Max. work pres. [kg]	1200
Weight [kg]	113

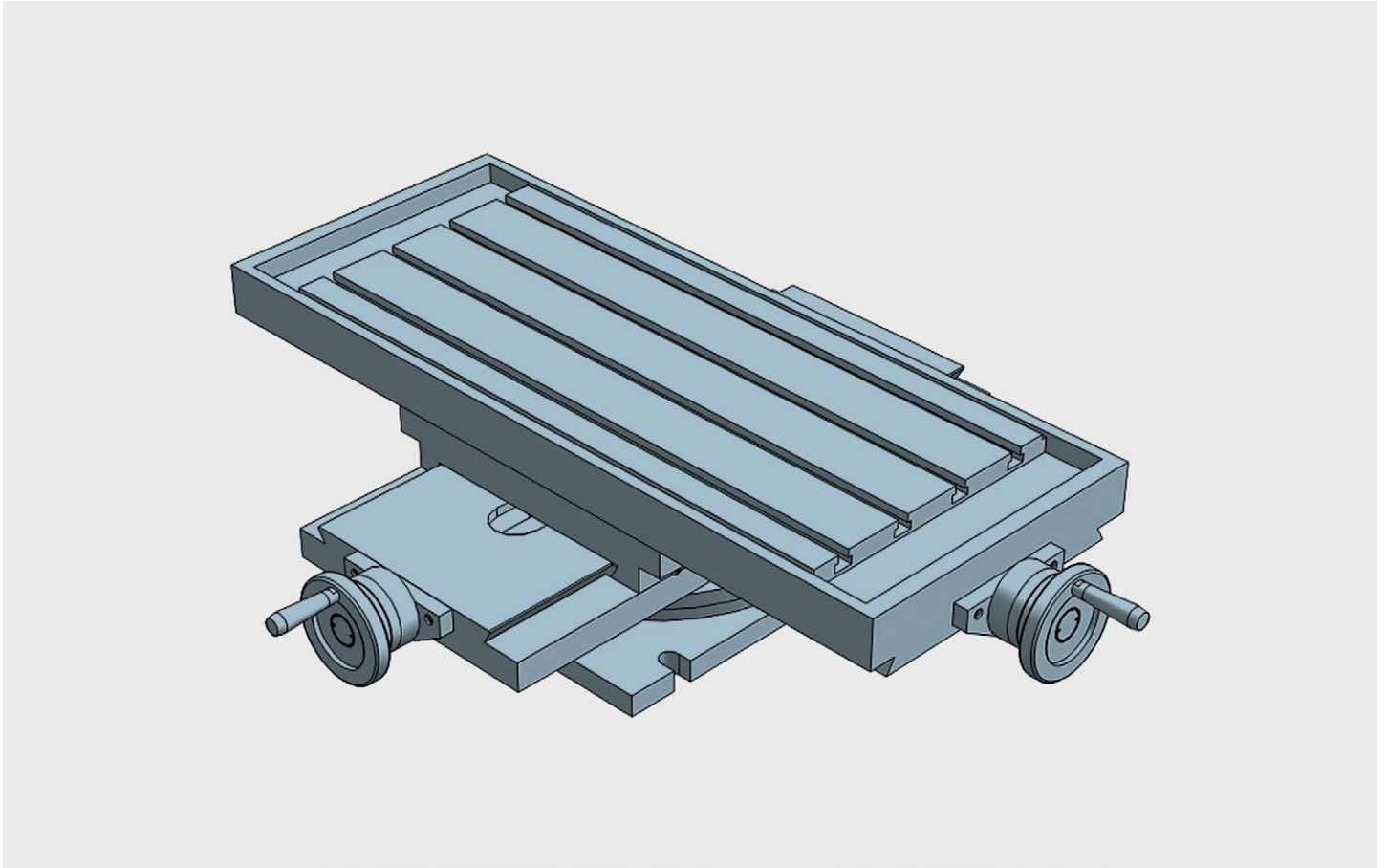

Double axis crosstable with rotary basis: the swivel support base comes with 180° in order to carry out angled works. All elements in stabilized cast iron GG25. All surfaces with grinded finishment. Millimetered rules in XY. Vernier/nonuis matt chrome. Dial, with zero setting. Spindle with trapezoidal thread. Adjustable spindle nut. Standard lock in XY (M6 screw to block the dovetailed guides in working position)

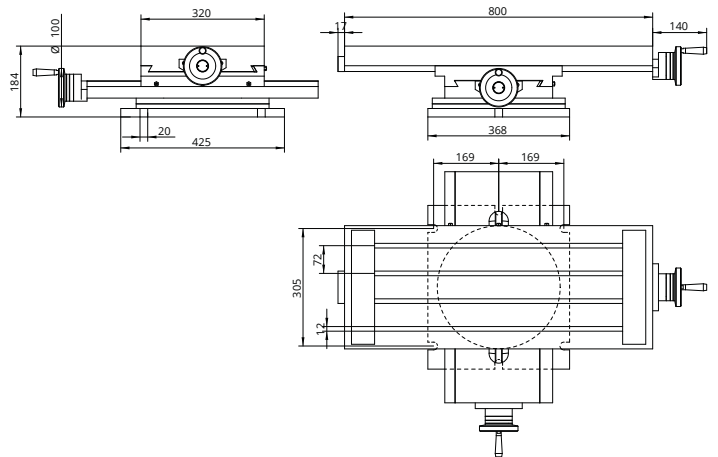

Rotary crosstable XY travelling 470x300

Technical Specifications

X - Travel [mm]	470
Y - Travel [mm]	300
Resolution [mm]	0,05
Max. weight [kg]	290
Max. work pres. [kg]	1200
Weight [kg]	126