

MINI Coordinate tables

MINI tables. Tables for applications in small mechanical operations and testing and metrology laboratories. Their compact design and highly sensitive movement make them extremely versatile in use.

Fixed X-axis MINI coordinate table with fixed base for small precision mechanics applications.

With a compact design and great sensitivity in movement, ideal for precision tasks, it can work both vertically and horizontally. The CP MINI series of coordinate tables is optimal for positioning, testing, metrology, roughness measuring, sensor movement, and any other small precision mechanics application where precise coordinate control is required.

The solid and compact design of the linear table allows a large number of jobs to be carried out while maintaining positioning precision and repeatability in any type of linear positioning. A perfect and common metrology coordinate table that guarantees a long service life.

All elements of the CP MINI series of manual coordinate tables are made of cast iron alloy (high-quality GG25 stabilized gray cast iron), which gives it extraordinary mechanical rigidity.

Technical details:

- Displacement by dovetails with clearance adjustment (all surfaces grinding finishment)
- Millimeter rulers and matte chrome vernier, with dial and zero adjustment.
- Triangular threaded spindle with adjustable spindle nut.
- Locking brake to fix the X table in its working position

The CP MINI series of coordinate tables offers 2 models of different sizes, with 50 and 100 mm of useful travel, in order to adapt to the needs of the application and offer flexibility and adaptation to different uses and applications: all types of machines - tool, drills, grinding machines, sharpening machines, mortising machines, lathes, linear optical and laser systems, positioning of work heads, adjustment and position regulation of parts in presses, displacement for welding cutting, industrial engraving.

BAZUS commitment:

- The highest quality, robust and durable coordinate tables on the market.
- Tables with the finest linear positioning and without spindle-play.
- Coordinate tables made 100% in Europe.

Customized solutions:

BAZUS, your trusted partner for high-performance positioning systems, provides the right solution for any application, specifically designed or customized to the characteristics and requirements of your activity.

Whatever your coordinate table, thanks to more than 100 years of continuous improvement, you will have a partner who offers solutions to all your positioning and movement requirements with many different applications available worldwide.

The first guarantee, for 5 years:

Why settle for a 2 year warranty? At BAZUS we believe that, if the coordinate tables do not expire at this time, neither should the professional attention received. So once again we want to change the rules. 5 year guarantee.

CP-100

CP MINI. X MINI table unit (horizontal or vertical)

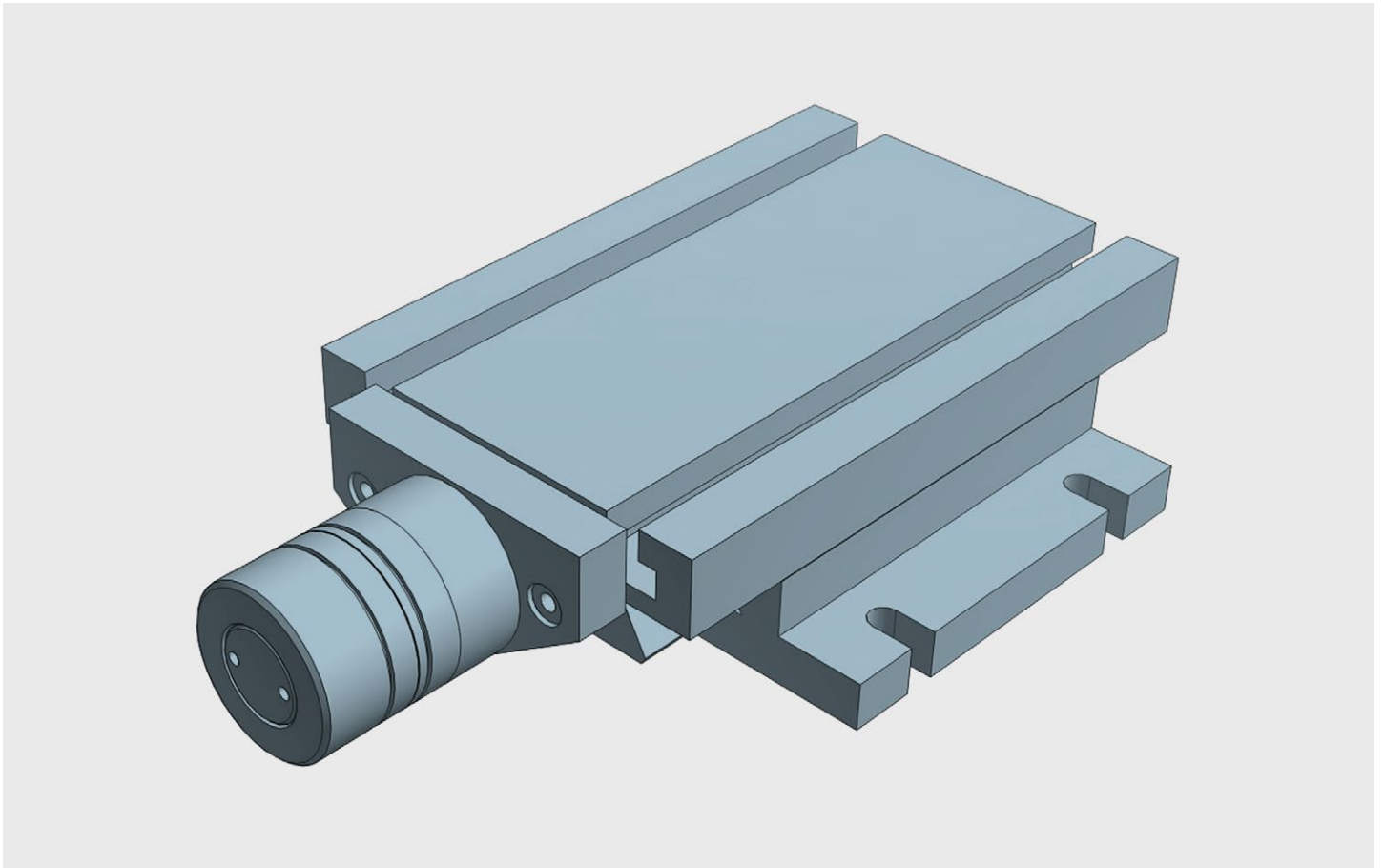

MINI single axis slide tables for applications in small mechanical operations, testing and metrology laboratories. Compact design and highly sensitive movements. All elements in stabilized cast iron GG25. All surfaces with grinded finishment. Millimetered rules in XY. Vernier/nonuis matt chrome. Dial, with zero setting. Spindle with triangular thread. Adjustable spindle nut. Standard lock in XY (M5 screw to block the dovetailed guides in working position)

"MINI" Slide table travelling 50

Technical Specifications

X - Travel [mm]	50
Y - Travel [mm]	-
Resolution [mm]	0,025
Max. weight [kg]	40
Max. work pres. [kg]	200
Weight [kg]	5

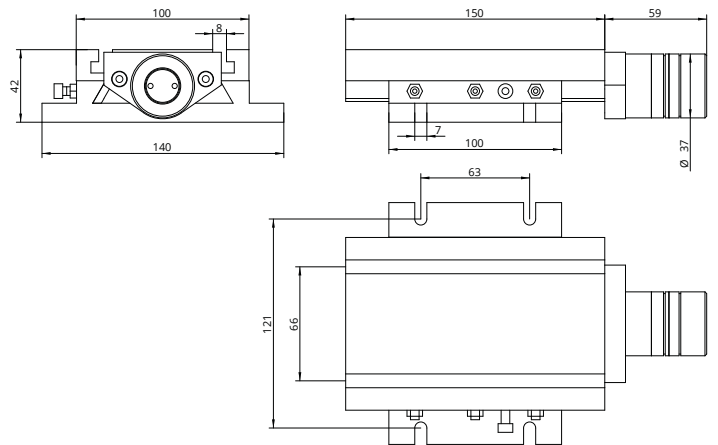

CP-200

CP MINI. X MINI table unit (horizontal or vertical)

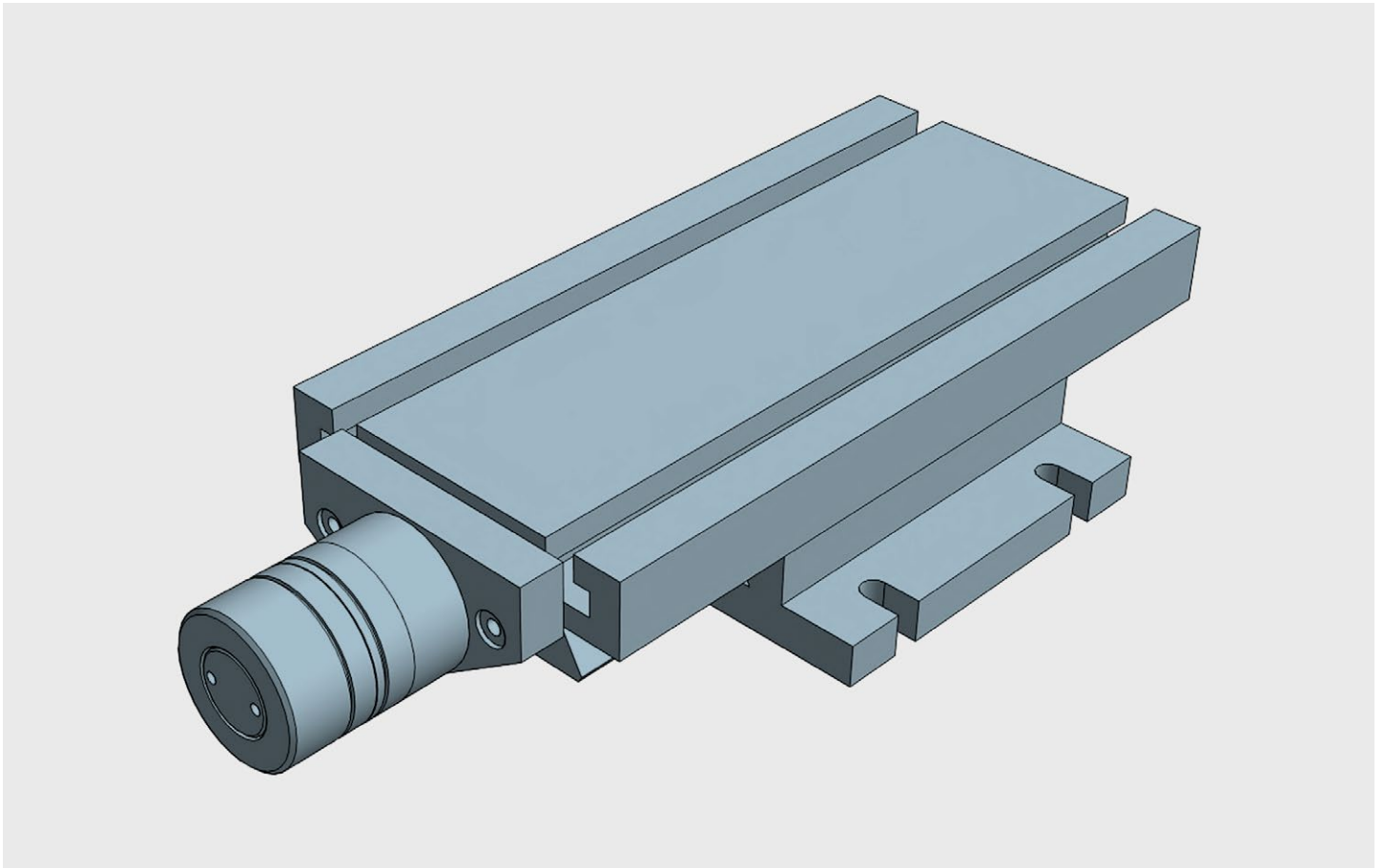

MINI single axis slide tables for applications in small mechanical operations, testing and metrology laboratories. Compact design and highly sensitive movements. All elements in stabilized cast iron GG25. All surfaces with grinded finishment. Millimetered rules in XY. Vernier/nonuis matt chrome. Dial, with zero setting. Spindle with triangular thread. Adjustable spindle nut. Standard lock in XY (M5 screw to block the dovetailed guides in working position)

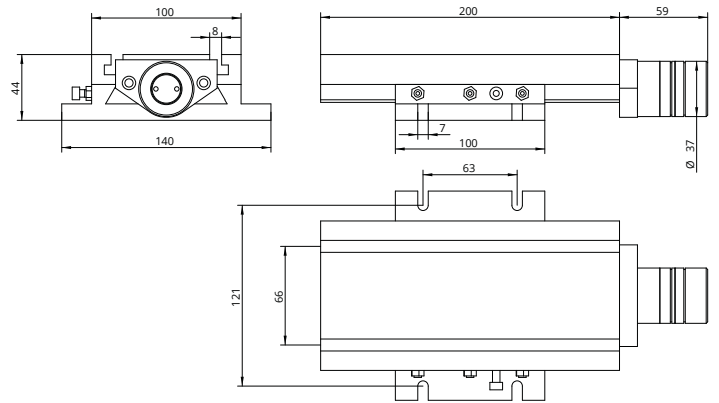

"MINI" Slide table travelling 100

Technical Specifications

X - Travel [mm]	100
Y - Travel [mm]	-
Resolution [mm]	0,025
Max. weight [kg]	40
Max. work pres. [kg]	200
Weight [kg]	5,5